

STARLIGHT RIDGE SOUTH HOMEOWNERS ASSOCIATION

ARCHITECTURAL CONTROL GUIDELINES

PREAMBLE

In order to maintain the architectural character and integrity of the community as well as preserve the value of the homes situated therein, it is necessary to enact and enforce the following Architectural Control Guidelines. The authority for the Architectural Control Committees (hereinafter "the ACC") to enact and enforce architectural control guidelines is provided by the Declaration of Covenants, Conditions, and Restrictions pursuant to Section 8, Architectural Control (b). A copy of said Declaration (hereinafter referred to as "the Declaration") was given to each owner when they purchased their home. Upon written request, the management company will provide a copy, if you do not have one. However, there will be a charge for such service. It is strongly recommended that you take the time to read and understand the Declaration and these guidelines as these documents in part determine both your rights and responsibilities. If there is any conflict between the Declaration and these Guidelines, the provisions of the Declaration shall prevail. The Board of Directors request strict observance and adherence to these Guidelines.

A. PURPOSE

Pursuant to Section 8, Architectural Control (b), of the Declaration of Restrictions for the Starlight Ridge South Homeowners' Association, Architectural Control Committee approval, must be obtained by the homeowner, before any improvements may be constructed or landscape installed. Certain exceptions have been granted in these Guidelines by decision of the Board.

This review is in no way intended to approve architectural requests for structural engineering or in lieu of required governmental permits or inspections, including all City Building Code requirements. The intent is (among other things) to maintain the *architectural* harmony and character of the Association.

B. APPLICATION AND REQUIRED COPIES

At least thirty (30) days before the intended start date owners shall present drawings, specifications, materials list, colors, dimensions and any other relevant information, including but not limited to, brochures, photos of similar Improvements and samples of materials to the ACC for study and approval. The ACC will respond in the timeliest manner to all requests for review, but reserves thirty (30) days from receipt of all required information as outlined herein to act on any application received.

Specifications and color samples as stated above must be submitted to the ACC. A fully completed and signed Architectural Approval Application form or any such other form must accompany all applications as the ACC may from time to time require.

All Drawings shall be prepared in accordance with the ACC's requirement, which follows. All plans and drawings shall be sent via; email: tarc@avalonweb.com, through the Avalon Homeowner Portal account,

or mailed to: Starlight Ridge South ARC Committee, c/o Avalon Management, 43529 Ridge Park Drive, Temecula, California 92590.

The Architectural Control Committee reserves the right to perform an on-site inspection before rendering a decision as to approval.

Failure to obtain necessary approval from the Architectural Control Committee shall constitute a violation of the Declaration and may require notification and/or removal at the homeowner's expense.

C. DRAWINGS

1. Plot Plan

- a. Show all lot lines accurately as lengths, angles, and curves.
- b. Show all dimensions on the work to be considered and distances between existing and new work and property lines. Show location of any impacted utility boxes, meters, hydrants, etc.
- c. Plans must show the facing walls of adjacent units. This is required so that the ACC has a clean definition of the placements of party walls with respect to adjacent neighbors.
- d. Your submittal must show the location of the bottom, toe or top of any slope.
- e. Show the plotted locations of drains, trees, shrubs, fences, patio cover, walls, spas and associated equipment, and all other structures.
- f. All yard drainage must include showing the direction of water flow and location of drainage swale/yard drain and point of discharge.

2. Roof Plan (Structural Additions Only)

- a. Show elevations and plans of all existing and new roof s with pitches noted.
- b. Show material of all existing and new roofs.

3. Floor Plan

- a. Indicate all walls, columns, openings and any condition or feature that will affect the exterior design of the building.
- b. Indicate exterior landscape or other details affected.

Drawings shall, in any case show the nature, kind, shape, dimensions, materials, and location of improvements to be considered.

D. GENERAL

1. When construction work requires the use of adjoining property, the applicant shall obtain written permission from the adjoining property owner. A copy of said permit must be filed with the request for ACC approval.
2. All work must be performed in a manner consistent with the appearance and general dwelling construction of the community.
4. Failure to obtain necessary approval from the ACC shall constitute a violation of the Declaration and may require modifications or removal at the homeowner's expense.

5. With respect to the approval process, the ACC reserves the right to an on-site inspection before rendering a decision.
6. In sections of the following detailed standards there appear lists of acceptable and unacceptable materials. These lists may not be all-inclusive and the ACC reserves the right to disapprove any material not listed in a homeowner's submittal.
7. **All work must be diligently pursued and must be completed within 180 days from the date of written approval from the ACC. Extensions may be requested in writing from the ACC, which shall have full discretion to grant such extensions on an individual basis.**

E. ARCHITECTURAL STANDARDS

The following fence criteria does not include Private Native Open Space, as per the CC&R's, Section 13 (m), fencing of any kind will not be permitted on any portion of the Private Property Native Open Space.

1. Fences and Walls

- a. For construction of private walls and fence, you are encouraged to use:
 - Substantial wood posts, beams and planks
 - Stud and stucco construction
 - Split face block (including unfinished, if the unfinished side is installed to face towards the installing lot.); exception: continuation of a developer installed block wall
 - Equestrian style fencing permitted
 - Materials used in combination such as painted wrought iron and split faced block.
 - Finished side of fences and walls to face the public side
 - Tubular steel painted a color to blend in with home
- b. Unacceptable materials for fencing are:
 - Aluminum or sheet metal
 - Chicken wire
 - Metal or plastic chain link (except within rear yards as dog run, etc.)
 - Plastic or fiberglass panels
 - Plastic webbing or strawlike materials
 - Wood grape stake
 - Glass block
 - Unfinished or uncoated cement or cinder block
- c. No double fences shall be constructed.
- d. Fencing shall not be constructed higher than six (6) feet. Walls and fences built on top a retaining wall will be considered separately from this restriction, with particular consideration for adjacent neighbors.
- e. Acceptable materials for the extension and repair of any wall or fencing shall be the original material and color only.
- f. Architectural Committee approval is not required for staining, painting, or weatherproofing of wood fences, so long as the material applied is either clear, closely matches the color of the stucco or wood siding on the home. Painting of wood fences to match any color other than the stucco, and siding color, is not permitted.

Individual Product Interior Wall/Fence Criteria

a. Open View Wall Base Application.

Where interior lot view opportunities exist without a privacy conflict, an open view fence or wall may be appropriate. Such a view fence shall be compatible with the architectural setting. An alternative painted tubular steel fence, or a tubular steel fence combined with another approved building material, is permitted.

b. Fence Base Application

Wood fence designs compatible with the architectural setting are permitted. Paint color selection shall complement the architectural setting. Owner wood fence features a board-on-board bracing and posts to present an identical appearance on all sides visible to the public.

2. The Board of Directors has devised **20 new approved color schemes** for Starlight Ridge South. The devised color schemes blend with the developers original colors. Owners may not deviate from the scheme selected, by example, the colors are listed for specific areas of the home, such as, stucco, accent, trim, siding and/or garage doors. The paint colors noted must be applied to said areas. Only one color scheme may be chosen and may not be intermixed with another color scheme.

The color schemes are displayed on Color Boards at Avalon Management, 43529 Ridge Park Drive, Temecula The Color Boards can be checked-out by Homeowner's for a 24 hour period. A deposit of \$25.00 is required for those that wish to check out a chart. Limit two charts, per check out, per Lot.

Prior approval from the Architectural Committee is required when choosing an approved color scheme. The ACC reserves the right to disapprove an approved color scheme if an adjoining neighbors home is painted with the same color or if the color has been used excessively on the applicants street. **Owners are limited to the approved color schemes and submittals to the Architectural Committee other than those of the approved color schemes shall not be approved.**

3. Cement Slabs and Walkways

Architectural Committee approval of cement slabs and walkways is not required where the following conditions have been met:

- a. The cement slab or walkway is located in the rear or side yard behind the owners' fencing and is of neutral color; brick, stone, and combinations of the foregoing are permitted providing they are of neutral color and complement the color, trim, and style of the house.
- b. All cement work not complying with the above must be submitted to the ACC for approval.
- c. Owners are required to obtain any necessary City permits and are responsible for ensuring proper drainage to the street.

4. **Screen doors**

Screen doors are permitted with out ACC approval, if the following requirements are met:

- a. Screen door design is to be compatible with the general architectural design of the house and must be consistent with the general appearance of the community.

5. **Antennas Installation Rules**

Antenna Size and Type

- a. Direct broadcast satellite (DBS) antennas that are one meter or less in diameter may be installed. Antennas larger than one meter are subject to the restrictions set out in Article 11, Section f of the CC&Rs and as may otherwise be contained in the governing documents of the Association.
- b. Multi-point distribution service (MDS) one meter or less in diameter may be installed. MDS antennas larger than one meter are prohibited.
- c. Installation of transmission-only antennas and all other antennas not covered by the FCC rule are subject to the restrictions set out in Article 11, Section f of the CC&Rs and as may otherwise be contained in the governing documents of the Association.

Location

- a. Antennas shall be installed solely on individually owned property as designated on the recorded deed or other document defining individually-owner property.
- b. Antennas shall not encroach upon common areas or other owner's property.
- c. Antennas shall be located in a place shielded from view from the street or the other lots to the maximum extent possible; provided, however, that nothing in this rule would require installation in a location from which an acceptable quality signal may not be received. This section does not permit installation on common property, even if an acceptable quality signal may not be received from an individually owned lot.
- d. If there are multiple locations where substantially the same acceptable quality signal can be received, the antenna must be placed in the location that is least visible to persons not on the owner's property. Preferred locations include rear yards, side yard locations adjacent to gas meters, heating and air-conditioning units, or screened among shrubbery.
- e. If the only location where an acceptable quality signal can be received is a highly visible location, then the antenna must be appropriately screened, provided signal quality is not diminished, by means, which do not unreasonable delay or increase the cost of the installation.
- f. When screening is required the screening should match the house or adjacent structure as to materials, finish, color and design. When landscaping is used for screening, it should match existing landscaping materials to the extent possible. The purpose of screening is to minimize visibility of the antenna.

Installation

- a. Antennas shall be no larger nor installed higher than is absolutely necessary for reception of an acceptable quality signal.
- b. All installations shall be completed so that they do not damage the common areas of the Association or the lot of any other resident, or void any warranties of the Association or other Owners, or in any way impair the integrity of buildings on Common Areas or lots.
- c. Owners are responsible for all costs association with the antenna, including but not limited to cost to:

- Place (or replace), repair, maintain, and move or remove antennas;
- Repair damages to the common property, other lots, and any other property damages by antenna installations, maintenance or use;
- Pay medical expenses incurred by persons injured by antenna maintenance or use;
- Reimburse residents or the Association for damages caused by antenna installation, maintenance or use.

Maintenance

- a. Owners shall not permit their antennas to fall into disrepair or to become safety hazards.
- b. Owners shall be responsible for antenna maintenance and repair.
- c. Owners shall be responsible for repainting or replacement if the exterior surface of antennas deteriorates.

Safety

- a. Antennas shall be installed and secured in a manner that complies with all applicable city and state laws and regulations and manufacturer's instructions.
- b. Unless the above-cited laws and regulations require a greater separation, antennas shall not be placed within two (2) feet of power lines (above ground or buried) and in no event shall antennas be placed where they may come into contact with electrical power lines. The purpose of this requirement is to prevent injury or damage resulting from contact with power lines.
- c. All installations must comply with all applicable codes.
- d. In order to prevent electrical and fire damage, antennas shall be permanently and effectively grounded.
- e. Antennas are required to be of such design as will readily withstand wind speeds to the extent that these may be reasonably anticipated in the immediate area in which the Project is located.
- f. Antennas may not obstruct a driver's view of an intersection or street.

Antenna Camouflaging

- a. Antennas or masts may not extend beyond a railing or fence unless no acceptable quality signal may be received from this location.
- b. Antennas situated on the ground and visible from the street or from other lots must be camouflaged by existing landscaping or fencing, if an acceptable quality signal may be received from such placement. If no such existing landscaping or screening exists, the Association may require antennas to be screened by new landscaping or screening or reasonable cost.
- c. Antennas, masts and visible wiring must be painted to match the color of the structure to which it is installed. (Some manufacturers assert that painting may prevent the receipt of an acceptable quality signal. Association residents are advised to measure the paint will not degrade the signal.)

Number of Antennas

No more than one antenna of each provider may be installed by an Owner.

Mast Installation

- a. Mast height may be no higher than absolutely necessary to receive acceptable quality signals.
- b. Masts that extend 12 feet or less beyond the roofline may be installed subject to the regular notification process. Masts that extend more than 12 feet above the roofline must be approved before installation due to safety concerns posed by wind loads and the risk of falling antennas and masts. Any application for a mast longer than 12 feet must include a detailed description of the structure and anchorage of the antenna and the mast, as well as an explanation of the necessity for mast higher than 12 feet. If this installation will pose a safety hazard to the Association residents and personnel, then the Association may prohibit such installation. The notice of rejection shall specify these safety risks.

- c. Mast installed on a roof shall not be installed nearer to the lot line than the total height of the mast and antenna structure above the roof. The purpose of this regulation is to protect persons and property that would be damaged if the mast were to fall during a storm or from other causes.
- d. Mast shall not be installed nearer to electric power lines than the total height of the mast and antenna structure above the roof. The purpose of this regulation is to avoid damage to and danger from electric power lines if the mast should fall in a storm.
- e. Masts shall not encroach upon another Owner's lot or common property;
- f. Masts are required to be of such design as will readily withstand wind speeds to the extent that these may be reasonably anticipated in the immediate area in which the Project is located.

Association Maintenance of Locations Upon which Antennas are Installed

- a. If antennas are installed on property for which the Association has a maintenance responsibility, Owners retain responsibility for antenna maintenance. Owners must not install antennas in a manner that will result in increased maintenance costs for the Association or for other residents. If such damage occurs, Owners are responsible for these costs.
- b. If maintenance requires antenna removal, the Association shall provide Owners with 10 days' written notice. Owners shall be responsible for removing antennas before maintenance begins. If Owners do not remove antennas by the required time, then the Association may do so at Owners' expense. The Association is not liable for any resulting damage to antennas.

Notification Process

- a. Any Owner desiring to install an antenna must complete a notification form and submit it to the ACC c/o Avalon Management. If the installation is routine (conforms to all the above rules and restrictions), the installation may begin immediately.
- b. If the installation is other than routine for any reason, Owners and the ACC must establish a mutually convenient time to meet to discuss installation methods. The owner is advised to contact the Association's property manager at (951) 699-6918 to arrange such meeting.

6. **Basketball standards and backboards** may be installed after ACC review and approval. Installations must comply with the following guidelines:

- a. Backboard or hoops may be mounted on the fascia board centered above the garage door. Backboards may not be mounted on homes or fences;
- b. Permanent basketball standards (e.g. post and backboard permanently anchored in the ground) planned for the front yard, should be planned so as to be situated along the edge of the driveway nearest to the side property line, and approximately midway between the garage and where the property meets the street;

7. **Play equipment** is permitted, without ACC approval, under the following conditions:

- a. No part of the equipment exceeds 8' in height;
- b. The equipment is placed at least 5' from any property line;
- c. Equipment to be placed in the side or rear yard behind the fence.

Play equipment includes gym or swing sets, slides, tetherball poles, etc. Equipment (such as skateboard ramps or half-pipes, playhouses, or similar play structures) not meeting the above guidelines must be submitted to the ACC for approval.

8. Window Treatment

- a. No window in any Residence shall be covered in whole, or in part, inside or outside, with aluminum foil, newspaper, paint, or any other material reasonably deemed inappropriate for such use by the Association; provided, however, an owner may use plain white sheets to cover windows for a period not to exceed 6 months after the close of escrow, pending the installation of shades, drapes, curtains, shutters, or other appropriate interior window coverings.
- b. An owner may tint the windows of his residence provided he obtains prior approval from the Architectural Control Committee. The use of reflective tint is allowed on all windows of the house. The guidelines for the type of reflective tinting to be used on the windows are no more than 20% solar reflectances and no less than 30% light transmittance. No bronze will be allowed. The degree of darkness allowed for non-reflective tinting shall remain with the Architectural Control Committee on a case-by-case basis. A brochure or manufacturer's description must accompany all tinting requests. All requests must include a sample of the material to be used. This sample will remain with the application and will not be returned.

9. Landscape

- a. All hardscape, which may include but may not be limited to; planters, concrete, and drainage systems, requires ACC approval. Rear yard plantings by an owner require the approval of the ACC only if the plantings involved exceed 8 feet in height, or due to growth habits of the plants involved, will grow to exceed 8' in height. All other rear yard landscaping or irrigation installation shall not require ACC approval.
- b. Trees, hedges and shrubs that restrict sight lines for vehicular traffic shall be trimmed back or removed.
- c. Landscaping of front yards, other than walkways, planter walls, or fences shall consist primarily of live plants.
- d. Shrubs, hedges, or trees requiring ACC approval under section a), above, which restrict neighbors' enjoyment of their lots, or which have root systems that may damage a neighbor's residence, require adjacent-neighbor notification.
- e. ACC approval is required for any mound added to the front or rear yard landscaping. No mound shall exceed two feet (2'-0") in height above original certified grade in any given location. Mounds shall be landscaped with grass, shrubs, ground cover, etc., to avoid erosion. Mounds shall not be installed against any property/perimeter line wall unless it has been designed as a retaining wall and has been sealed to avoid leaching.

10. Drainage

- a. All drainage from improvements shall be constructed to return drainage to the front street. No drainage pattern shall be altered to cause drainage to flow over neighbors' property or on any slope. All drainage must be cored through the curb, and may not run over the City sidewalk. City sidewalks may not be broken to lay drainage.

11. Patio Covers (Including Gazebos)

Patio covers require ACC approval and must comply with the following guidelines:

- These improvements shall meet all code requirements and should be of wood construction with the exception of vertical supports. Other material products that look like wood may be

allowed on a case by case basis. Samples of the product and structural/weather resistant data must accompany the application.

- Second story decks not built by the merchant builder will be considered on a case by case basis with adjoining homeowner view line and privacy in mind.
- Solid roof covers shall be in harmony with primary home, e.g. color & style. Alternative wood materials may be approved/allowed on a case by case basis.
- Exposed surfaces must be painted to match the exterior of the home. No accent colors will be allowed.
- If any lighting is added on patio covers, gazebos or second story decks it must **not** be directed onto or at your neighbor's yard or house.
- The patio cover setback is to be no less than the side wall of the existing home or 6' from the side property line and 6' from the rear of the property line.

Unacceptable materials include:

- Raw material (plywood or exposed metal);
- Corrugated plastic or fiberglass;
- Plastic webbing, reed or straw like materials

12. **Storage sheds**

Storage sheds are permitted with ACC approval, and must meet the following requirements:

- a. Shed to be constructed of wood or metal; roof color must closely match the color of the house roof. Shed must be located in the rear or side yard behind the fence line so as not to be materially visible to the public.
- b. Shed to be a completely enclosed structure with entry door(s).
- c. Shed design and construction are to be compatible with the architectural design of the house must be consistent with the general dwelling construction and appearance of the community.
- d. Paint of shed shall match paint of house in color and proportions (i.e., to match body and trim color).
- e. Shed may not exceed six feet in height at eaves and no more than eight feet at highest point of roof. Shed may not exceed more than 100 sq. ft.
- f. Shall conform to City Building codes.
- g. The applicant shall obtain written permission from adjoining property owner(s) and Owner's whose line of sight may be affected by the shed. A copy of said permission shall be filed with the request of architectural approval.
- h. The Architectural Control Committee reserves the right to perform an on-site inspection before rendering a decision as to approval.
- i. Failure to obtain necessary approval from the Architectural Control Committee shall constitute a violation of the Declaration and may require notification and/or removal at the homeowner's expense.

13. **Outside Decorations**

- a. Holiday decorations are generally permitted without ACC approval, provided they are erected for not more than six (6) weeks in any 12-month period and are put out no earlier than one month prior to the holiday and removed within two (2) weeks after the holiday. For this

purpose, decorations shall refer to theme items, including lights installed on the exterior of the residence and landscaping.

- b. All outside ornaments or decorations erected or intended to be erected for a longer period than permitted in 13(a) above and which are visible from the street must have prior approval of the ACC.

14. **Solar Powered Energy Systems**

- a. Solar powered energy systems are encouraged as a matter of public policy. The Association respects the national interest in this matter. However, aesthetic concerns do exist, and therefore the Association implemented certain minimal guidelines to preserve the aesthetic integrity of the neighborhood.
 - 1. All solar equipment shall be reviewed and approved by the Architectural Control Committee. Color brochures or the equivalent shall be required for the review process. All such systems require adjacent neighbor notification.
 - 2. A solar energy system shall meet applicable health and safety standards and requirements imposed by state and local permitting authorities.
 - 3. A solar energy system for heating water shall be certified by the Solar Rating Certification Corporation (SRCC) or other nationally recognized certification agencies. SRCC is a nonprofit third party supported by the United States Department of Energy. The certification shall be for the entire solar energy system and installation.
 - 4. A solar energy system for producing electricity shall also meet all applicable safety and performance standards established by the National Electrical Code, the Institute of Electrical and Electronics Engineers, and accredited testing laboratories such as Underwriters Laboratories and, where applicable, rules of the Public Utilities Commission regarding safety and reliability.

15. **Miscellaneous**

- a. Plans for **dog runs** along fence or property lines require adjacent-neighbor notification. Neighbor input will be strongly considered.
- b. **Accessory Dwelling Unit (ADU) or Junior Accessory Dwelling Unit (JADU)**
Owners may lease out their Lot or Residence or an accessory dwelling unit ("ADU") or junior accessory dwelling unit ("JADU") on their Lot. Any such lease shall be subject to the CC&Rs and other governing documents. An ADU or JADU may be installed upon prior application to and receipt of architectural approval from the Association pursuant to Article 8 of the CC&Rs and receipt of approval and a permit from the City of Temecula.
- c. **Security bars** visible from the exterior on windows and doors will be evaluated on an individual basis.
- d. **Blinds, rolled shutters nor sunshades** are not permitted on the exterior of the front window.
- e. Exterior landscape/walkway **lighting** must be low voltage (12V). Higher voltage light will be approved if it is not directed, or if it is placed so that it does not create an annoyance to the neighbors.
- f. **Pools, spas, and related equipment** will be considered on an individual basis and requires adjacent-neighbor notification.
- g. Architectural Committee approval is not required for installation of **rain gutters** as long as they closely match the color of the trim (fascia board); all downspouts must closely match the stucco or siding color.

- h. Replacement of the existing wooden swing up **garage doors** is allowed. The new door must match the existing trim paint as closely as possible.
- i. **All mailboxes, including locking mailboxes shall be** black and shall be of the standard round-top design. With regards to the post design, see the following Mailbox and Post Specifications, the post material, color, and the dimensions including height, may not be revised. Homeowners are responsible in keeping their mailbox and the post thereof in good repair, including repainting as necessary. (Should a particular post require maintenance all property owners that share the respective post will be notified.)

Mailbox dimensions shall conform to the basic rural mailbox of 19” (depth) x 9 3/4” (height) x 6 3/4” (width). Locking mailbox size shall not exceed 22.25” (depth) x 11” (height) x 10 3/4” (width).

Posts shall be of wood construction and shall meet the dimensions of Exhibit A (attached). However, if a property owner prefers to install a locking mailbox the property owner must revise the horizontal piece on both sides of the post to a total length of 32” pursuant to Exhibit A (attached). The post shall be painted Bone White (Dunn-Edwards Paint).

F. REMEDIES

If, upon the expiration of thirty (30) days from the date on which an owner is notified of a violation of these Guidelines, said owner has failed to remedy the non-compliance, the Board of Directors shall notice the offending party on a date and time for a hearing in writing. After affording such owner notice and hearing, the Board shall determine whether there is a noncompliance of the Declaration and, if so, the nature thereof. If a non-compliance exists, the owner shall remedy or remove the same within a period of not more than forty-five (45) days from the date of announcement of the Board ruling of noncompliance. If the owner does not comply, the Board will initiate reasonable and appropriate actions, including fines, to see that non-complying improvements are removed.

G. VARIANCE

The Architectural Committee may authorize variances from compliance with any architectural provision contained in the Guidelines on height, size, floor area, or similar restrictions when circumstances such as a topography, natural obstructions, hardship, aesthetic, or environmental considerations may justify such variances.

H. APPEAL PROCEDURE

In the event that plans and specifications submitted to the Architectural Control Committee (ACC) are disapproved, the party making such submission may appeal in writing to the Board. The Board must receive the written request not more than thirty (30) days following the final decision of the ACC. The Board shall submit such request to the ACC for review, and the written recommendation of the ACC will be submitted to the Board. The review of the Appeal will then take place at a duly noticed open meeting of the Board of Directors. Within sixty (60) days following receipt of the request for appeal, the Board shall render its written decision. The failure by the Board to render a decision within said sixty (60) day period shall be deemed a decision in favor of the party making such submission.

“Exhibit A”

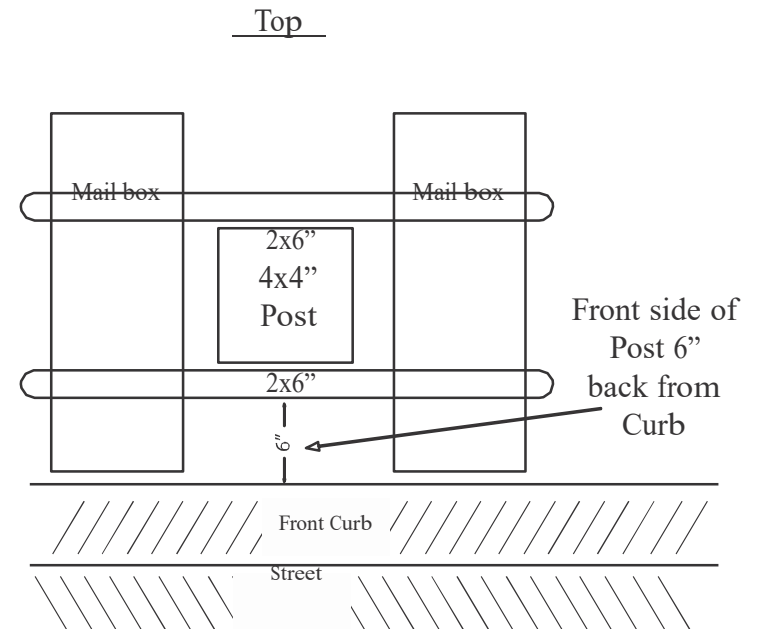
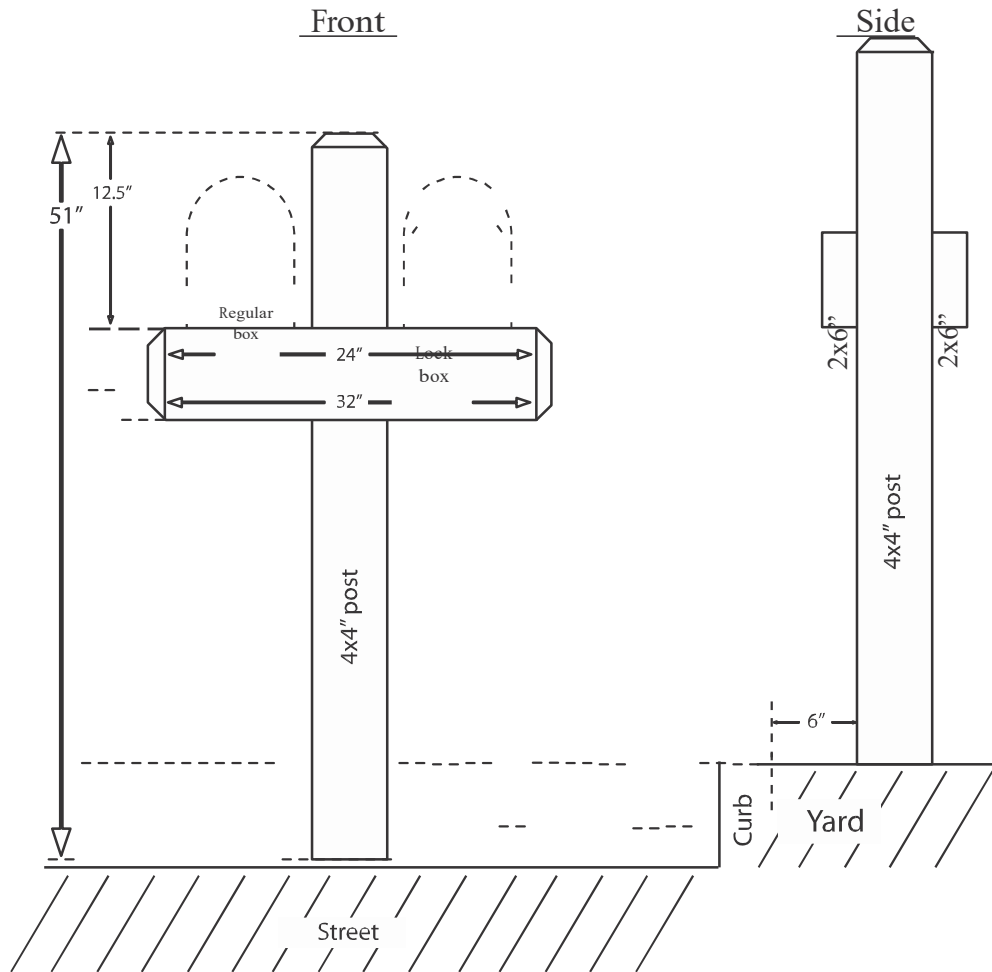

Note

Use 3/4" wood or plywood
1/2" narrower than box width
under mail box
Fasten to 2"x6" then
place mailbox on top
fasten box on sides

Colors

Mail Box shall be Black
Post shall be Dunn-Edwards Bone White